

## 2010 B-Cadet (Sportsman)



All cars must have wrecker hookup. All cars should have 5 pound minimum fire extinguisher in reach of driver. All drivers should wear flame retardant fire suit, shoes and gloves. Window nets are highly recommended. No radios, communication equipment or mirrors, including pit boards. No computer controlled equipment allowed on any car.

All parts specified as OEM/stock manufactured must be standard option parts or equivalent aftermarket parts and must be readily available from car dealer or any auto parts store. Casting numbers must remain on all OEM/stock parts.

Rules that state ALL CARS or rules that are not weight-specific apply to all cars. Cars receiving weight breaks must meet all Motor, Carburetor, Transmission and Frame specifications listed with the designated weight. Cars with ANY one or more of the following modifications must weigh 3,200: offset frames, non-crate racing transmissions or non-crate OEM transmission without working OEM torque converter, non-crate triple disc clutch, ci greater than 408, setback over 1", roller cams or lifters, ported or polished heads and intakes (except 3/4" port matching), aftermarket lower-a arms, 3-link suspension, panhard bars or lift bars.

### 1. MODEL CARS

1960 to current year passenger cars. No type of truck, station wagon, front-wheel or 4-wheel drive. No convertibles, t-tops or open sunroofs.

### 2. MOTOR

ALL CARS—V8 motors only. Motor must be stock appearing. 1 spark plug and 2 valves per cylinder. Cast iron or aluminum intake. Any type steel or aluminum pistons permitted. No titanium or exotic metal parts. No fuel injection, turbo chargers or blowers. No dry sumps.

Open 3,200 weight—Cast iron block and any cast iron heads. Any cam permitted. 4" maximum motor setback measured from left front spark plug to center of ball joint.

Standard 3,050 weight—408 cubic inch limit. Cast iron block and any cast iron heads. No porting or polishing heads or manifold except port matching of the intake runner 3/4" from the manifold interface is permitted. No roller cams or lifters. No dry sumps. 1" maximum motor setback measured from left front spark plug to center of ball joint.

Spec 2,900 weight—362 cubic inch limit. OEM stock cast iron block. OEM stock cast iron heads, RHS #12407 or World Product cast iron heads #4265, #4266, #4267 or #5303. No angle plug heads. No high performance blocks, heads or intakes (Bowtie, W2, GT40, SVO, Performance, etc.). Vortec #25534371 and #25534351 are not permitted. No porting or polishing heads or manifold except port matching of the intake runner 3/4" from the manifold interface is allowed. Any non-high performance, OEM cast iron or aluminum, dual or single plane intake or Edelbrock #2101, #2116, #2181, #2901, #2912, #2913, #2915, #2924, #2925, #2940, #2941, #2975. #5001, #5021, #5076 and Victor Jr Sportsman 2V, Weiand #7515, #7545, #7547, RPM #7101 or Mercruiser cast iron intake. No roller cams or lifters. Steel crankshaft with stock stroke. Steel rods. No dry sumps. 1" maximum motor setback measured from left front spark plug to center of ball joint.

Crate 2,750 weight or Crate 2,900 weight—GM crate motor part #88958602. No dry sumps. 1" maximum motor setback measured from left front spark plug to center of ball joint. 9.1:1 maximum compression ratio.

Crate motor must be purchased from an authorized dealer and MUST remain sealed at all times. GM factory encrypted bolts cannot be altered, removed or changed except by an authorized repair center. Absolutely no modification or changing of any internal engine part. No machine work permitted. GM part number may not be removed. Any motor modification will result in one year suspension and loss of all points and winnings. Any GM bolts that have been copied are considered trademark infringement and will be reported to the manufacturer for legal proceedings. Motor service or reassembly after tear down may only be performed at an authorized repair center and motor must be resealed with GM factory encrypted bolts. All motor repairs must be done with the same exact GM motor parts, listed in GM book part #88958668. By using a crate motor in competition, the race team acknowledges all responsibility for the legality of the motor upon inspection at any event regardless of any previous motor verification.

### 3. BODY

Body must be stock appearing and meet all specifications listed on diagram. Body and deck must have a flowing line from front to rear. 40" maximum deck height. 48" maximum rear quarterpanel length measured from center of rear wheel including bumper. 4" minimum ground clearance. 2" minimum clearance around wheels. No ridges, fins or raised edges on body except roof bead rolls.

Fenders must be level from side to side. Quarterpanels must be same length and cannot extend higher than rear deck. Rear deck must extend between quarterpanels and may not extend past quarterpanel. Skirting may not extend behind quarterpanel. Quarterpanels and doors may not dish inward.

80" maximum body width at all points. All fenders, doors and quarterpanels should roll inward 1/2" to 1" at top, with sides over upper body. No sharp or jagged edges, fasteners, etc. No wings or tunnels permitted under body or chassis. Unapproved bodies may be assessed a 50 pound weight penalty.

### 4. ROOF

Minimum 44" long x 48" wide. Maximum 60" long x 60" wide. 45" minimum height from ground. Roof must be mounted near center of car, parallel to deck and level. Roofline and side panel window contours should be stock appearing and match nosepiece. Roofline should be rounded—no, wedge, bellied or hollow roofs. Flat roofs may have 2" maximum height variance from front to rear. Rounded roofs may drop 5" at the front and 2" at the rear from the break point.

Rear roof and front roof supports mandatory. Rear roof supports may extend 41" from rear of driver's side window. Rear roof supports may extend 15" maximum behind center of axle. Rear roof supports must taper downward evenly both to the rear and side with a 2" maximum outward bow. 17" maximum at top of rear roof support. 10" high x 15" long minimum rear support window is optional and recommended for appearance. Rear support window may be filled with clear lexan. 2" minimum front roof post width, 4" maximum. Front roof post braces may extend 7" vertical and horizontal.

12" minimum door window opening height measured from deck to roof. 1.5" maximum roll down permitted along front and rear edge of roof. 1/2" maximum bead rolls permitted on roof running from front to rear in direction, 4 maximum including edge bead rolls. Unapproved roofs may be assessed a 25 pound penalty.

## 2010 B-Cadet



### 5. NOSEPIECE, HOOD AND BUMPER CAP

Molded stock appearing nosepiece required made of flexible material. **15"** minimum nosepiece height measured from bottom of nosepiece to where sheet metal is attached, following the angle of the nosepiece. **Must** be mounted level. **52"** maximum nosepiece extension including front bumper measured from center of front hub with wheels turned straight. **80"** maximum nosepiece width. Fender flare cannot extend higher than fender. **4"** minimum ground clearance. **25 pound penalty for unapproved nosepieces.**

Hood should be secured by **3** hood pins. Rear of car must be completely enclosed from deck to top of bumper, **10"** minimum height. Rear panel must extend from quarterpanel to quarterpanel and must be solid sheet metal.

### 6. SPOILERS *Spoiler measurements may be adjusted during the season for competition.*

Cars with **8"** tires may run **8"** maximum vertical spoiler height measured from top of rear deck and 8" maximum spoiler length measured along the angle of the spoiler. **8"** maximum side spoiler height from rear of side spoiler to **6"** forward of rear of side spoiler. **3"** maximum height at front of side spoiler. **12"** maximum side spoiler length. Spoiler may be no wider than deck. No spoilers on any kind on cars with tires wider than 8". No other spoilers, ridges or wings permitted on any car.

### 7. TIRES

**11"** maximum tire treadwidth. **16 3/4"** maximum cross section. Tires must have all manufacturer's stamps intact. Hoosier **27.5/8/15** hard or **RC4**, **26.5/8/15** hard or **RC4** or any Hoosier **1600**, **D55** or **LM40** only. **64** minimum hardness verified by durometer. Track durometer is the official measuring tool of tire hardness regardless of stamp. **No** chemical treating of tires. Tires may be impounded for tech.

### 8. WHEELS

**10"** maximum steel only. **No** aluminum, plastic wheels or carbon fiber wheels. **Beadlocks—OK.** **Wheels** must be held on by bolt-type lug nuts, no knock-off type mounting permitted.

### 9. CARBURETOR

Holley **#3310S** or OEM quadrajet **4**-barrel must be used on all cars.

### 10. FUEL

Gasoline only. **No** alcohol, nitrous oxide, nitro-methane or propylene oxide. **No** electric fuel pumps or pressurized fuel systems. **Mechanical** or belt-driven fuel pumps only. Fuel lines should not pass through driver's compartment.

### 11. DISTRIBUTOR

**No** magnetos permitted on any car. **OEM** stock distributor or **MSD** systems allowed. **HEI** permitted.

### 12. FRAME

**ALL CARS—104"** minimum wheelbase. **Complete** stock production snout required to **20"** behind rear of ball joint. **Snout rails** may not be modified. **Cross member** may be modified for clearance only. **Tubing back-half—OK.** **Tubing frame** must run above axle. **No round frame rail tubing.** **Car** should have horizontal safety bar constructed from same steel tubing as frame, mounted behind fuel cell and securely welded to frame. **Rear bumper** should be at least **4"** behind fuel cell. **Center of rear bumper and safety bar** should be at rear deck center height, approximately **19"** from the ground and should be at least as wide as frame. **Tubing** should also extend downward to form a horizontal bar at the bottom height of the fuel cell, with additional vertical and diagonal tubing bracing the lower tubing to the rear bumper and the safety bar. **Lower tubing** should be at least as wide as fuel cell. **No** part of the fuel cell should be below the protective tubing. **Any bumper** that extends more than **8"** from the rear of frame should be rounded and directed toward the front of car. **Loop-style rear bumpers—OK.** **Bumper** should not have any sharp edges. **No** external rub rails. **All frame tubing** should be constructed of minimum **2"** wide x **3"** high square steel tubing, with **.120"** minimum material thickness. **No** holes may be cut in frame. **All other chassis tubing** should be **1 1/2"** to **1 3/4"** outside diameter and minimum **.083"** thickness.

**Unibody frames** using rear subframe should have full snout and rear subframe connected by minimum **2"** wide x **3"** high steel rectangular tubing connector rails with **.120"** minimum wall thickness. **Unibody connector rails** should be connected to the back of the front snout and the front of the rear subframe. **No** holes may be cut in frame or connectors. **Unibody frame** may be shortened in the tub area, but complete front subframe must remain stock.

**Open 3,200 weight—Offset frame—OK.**

**Standard 3,050, Spec 2,900, Crate 2,900 or Crate 2,750 weight—No offset frames allowed.**

### 13. SUSPENSION

**ALL CARS—**Racing springs, racing shocks and aftermarket, tubing upper a-arms and aftermarket trailing arms—**OK.** **Weight jacks—OK.** **No** coilovers. **No** driver-controlled weight jacking equipment or computer or electronic suspension components. **No** straight front axles.

**Open 3,200 weight—Panhard bars, lift bars, aftermarket lower a-arms, and 3-link suspension—OK.** **No 4 or z-link suspensions.** **No other torque absorbing equipment.**

**Standard 3,050, Spec 2,900, Crate 2,900, Crate 2,750 weight—** Lower a-arm must be OEM stock and in stock position. **No 3, 4 or z-link suspensions.** **No** panhard bars. **No** lift bars or torque absorbing equipment of any kind.

### 14. TRANSMISSION, DRIVE SHAFT & CLUTCH

**ALL CARS—**Transmission should have explosion-proof bell housing or **360** degree **1/2"** steel scatter shield securely mounted to car. **No** in and out boxes. **Standard** transmission must have operational clutch. **Clutch** should have scatter shield. **Transmission** should be bolted to the motor and must have working reverse gear. **Only one** drive shaft permitted. **All** drive shafts should be painted white and should be surrounded by two **3"** steel safety loops or sling mounted to frame.

**Open 3,200 or Crate 2,900 weight—**Racing transmission allowed. **OEM** transmission without working OEM torque converter—**OK.** **Triple disc clutch permitted.**

**Standard 3,050, Spec 2,900 and Crate 2,750 weight—**Transmission must be OEM stock and automatics must have working OEM torque converters. **No triple disc clutch.**

## 2010 B-Cadet



### 15. REAR AXLE

Any type stock production rear end. Floater—OK. Locked rear end—OK. 9" rear end permitted. No quick changes.

### 16. TRACTION CONTROL

All traction control devices using wheel sensors are NOT permitted. Adjustable ping control devices, dial a chip controls, timing controls or automated throttle controls are NOT allowed in the cockpit or any other location accessible by driver. Any remote control components or data acquisition equipment are NOT permitted.

### 17. BRAKES

All cars must have 4 wheel braking system.

### 18. EXHAUST

Headers permitted. Exhaust pipes may NOT point towards ground. Mufflers are HIGHLY recommended for all cars.

### 19. STARTER AND BATTERY

All cars must be self starting. Failure to start during a race will result in disqualification. Battery should be located in a safe area and covered with a metal fireproof box. Battery should not be in driver compartment. Battery disconnect kill switch to shut down motor highly recommended, mounted in reach of driver and should be clearly labeled for safety crew.

### 20. ROLL CAGE

4-post, box-type roll cage should be constructed of 1 1/2" minimum outside diameter and .095 minimum thickness steel tubing. Roll cage should have at least 3 horizontal bars at driver's side door and 2 horizontal bars at passenger side door, extended outward into door panels with 2 vertical bars between each horizontal bar as additional support. An extra vertical side brace bar is recommended on the left side in line with steering wheel. Door bars should be 1 1/2" in diameter with a minimum thickness of .065. Both door window areas should remain open and unblocked by roll cage bars for easy exit. Roll cage should extend forward on driver's side to protect foot area completely. Roll cage should be welded to frame in at least 6 places (in addition to diagonal bracing) and welded together at all intersecting points. Diagonal bars should brace roll cage at rear, and should run from frame to top of roll cage.

Top of roll cage should be at least 2" above top of driver's helmet. All areas of the cockpit should have at least 11" of clearance below the roll cage and roof. All roll cage bars within reach of driver should be covered with non-flammable foam padding. Other than padding, roll cage must remain exposed above top of door with no aerodynamic effects. Right-side padded headrest or head net recommended attached to roll cage. Bars or wire mesh in windshield and driver's side quick-release window net highly recommended.

### 21. FUEL CELL

22 gallon maximum, racing-approved fuel cell should be securely mounted inside a 20 gauge steel or .060" aluminum metal box and secured to frame with a minimum of two 2" x 1/8" thick steel straps around entire fuel cell. Minimum 7/16" bolts should be used to mount the fuel cell. The fuel pick up should be on the top or right side of the fuel cell, be constructed of steel and should have a check valve in case of roll over. Fuel cell should be mounted in square tubing frame. Fuel cell should be mounted behind the rear axle and between the rear tires, at least 4" in front of the rear bumper. 9" minimum fuel cell ground clearance. No part of the fuel cell may be lower than the rear end housing. Car number must be displayed on fuel cell, 6" minimum height.

### 22. FIREWALLS AND INTERIOR

A full metal firewall at front, rear, sides and floorboard should be joined to seal off driver compartment. Full metal floorboard. Top of interior to top of doors should be 3" maximum. Interior should be mounted flush with outside body panels. 12" minimum interior clearance below roll cage at all points for easy exit.

### 23. SEAT AND SAFETY BELT

Metal racing-approved seat with padded headrest should be securely attached to frame. 3", 5-point, quick release racing belt with double harness should be bolted to frame or roll bars. Mounts should run in the same direction to secure the belt. Belt should not come in contact with sharp edges. Safety belts should be replaced if two years old, and all worn or damaged safety belts should be replaced. Quick-release, racing-type steering should be used.

### 24. FIRE SUIT AND HELMET

Drivers should have flame retardant firesuit and racing approved full-face helmet with face shield. Nomex shoes, gloves, and hood highly recommended. Neck collars and arm restraints recommended.

### 25. WEIGHT *Weight limits may be adjusted during the season for competition.*

3,200 pound minimum weight with driver after race for cars meeting Open specifications. 3,050 pounds for cars meeting all Standard 408 specifications. 2,900 pounds for cars meeting all Spec 362 specifications or Crate motor cars with racing transmission or without working OEM torque converter. 2,750 pounds for cars meeting all 602 Crate specifications. No tolerance. All weights should be solid material, entirely painted white or a bright color and marked with car number. Each weight should be 50 pound maximum. Weights should be bolted to frame with two 1/2" Grade 5 bolts on two weight clamps or secured with steel plate. No weights should be attached to rear bumper or in driver's area. Weights should not be lead pellets or liquid. Each weight should be bolted to the frame individually and should not be stacked on another weight.

**RULEBOOK DISCLAIMER:** The rules and/or regulations set forth herein are designed to provide for the orderly conduct of racing events and to establish minimum acceptable requirements for such events. These rules shall govern the condition of all events, and, by participating in these events, all participants are deemed to have complied with these rules. NO EXPRESSED OR IMPLIED WARRANTY OR SAFETY SHALL RESULT FROM PUBLICATIONS OF OR COMPLIANCE WITH THESE RULES AND/OR REGULATIONS. They are intended as a guide for the conduct of the sport and are in no way a guarantee against injury or death to a participant, spectator or official. The race director shall be empowered to permit reasonable and appropriate deviations from any of the specifications herein or impose any further restrictions that in his opinion do not alter the minimum acceptable requirements. NO EXPRESSED OR IMPLIED WARRANTY OF SAFETY SHALL RESULT FROM SUCH ALTERATION OF SPECIFICATIONS. Any interpretation or deviation of these rules is left to the discretion of the officials. Their decision is final.

## 2010 B-Cadet GM Crate Motor Specs



### GM 602 350/350

Block part number	<b>#10105123</b>
Block type	cast iron with 4-bolt main caps
Bore x stroke (in)	<b>4.00 x 3.48</b>
Camshaft duration (@.050 in)	<b>212</b> degree intake / <b>222</b> degree exhaust
Camshaft lift (in)	<b>.435</b> intake / <b>.460</b> exhaust
Camshaft part number	<b>#24502476</b>
Camshaft type	hydraulic flat tappet
Compression ratio	<b>9.1:1</b>
Connecting rod part number	<b>#10108633</b>
Connecting rods type	powdered metal steel
Crankshaft part number	<b>#14088526</b>
Crankshaft type	nodular iron
Cylinder head part number	<b>#12558060</b>
Cylinder head type	vortec iron; <b>64cc</b> chambers
Displacement (cu in)	<b>350</b>
Engine name	Circle Track <b>350/350</b>
Engine type	Chevy small-block <b>V-8</b>
Ignition timing	<b>32</b> degree total @ <b>4000</b> rpm with vacuum advance disconnected
Maximum rpm	<b>5500</b>
<b>NOTE</b>	Distributor included with <b>350/350</b> engine has melonized steel gear part number <b>#10456413</b> . This <b>MUST</b> be used with engines with steel camshafts, or engine damage will occur.
Piston part number	<b>#12514101</b>
Pistons type	hypereutectic aluminum
Recommended fuel	<b>92</b> octane
Rocker arm ratio	<b>1.5:1</b>
Rocker arms part number	<b>#10089648</b>
Rocker arms type	stamped steel
Valve size (in)	<b>1.94</b> intake / <b>1.50</b> exhaust

# 2010 B-Cadet Body Specifications



Spoiler and side spoilers permitted only on 8" tire cars.

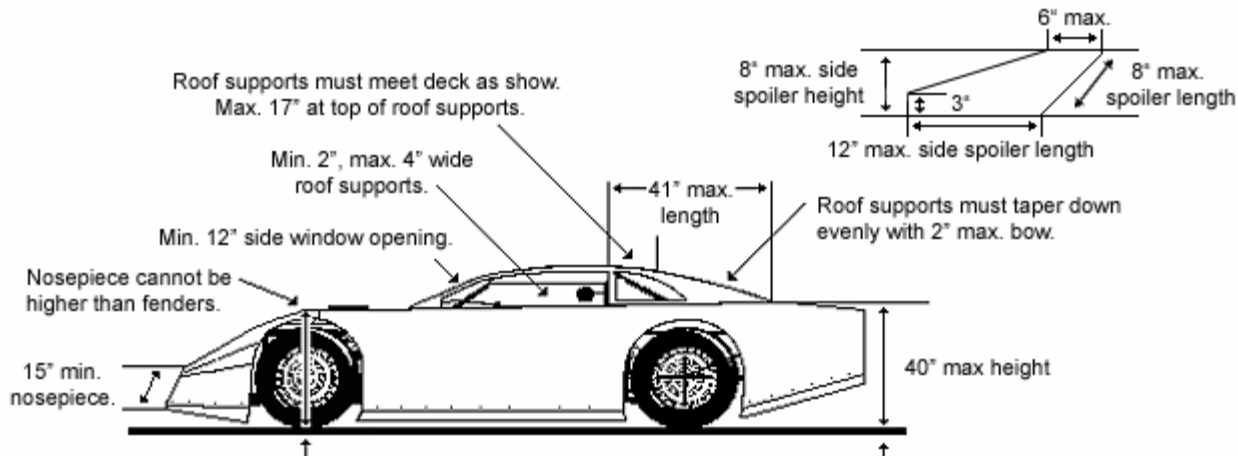

If deck height is over 40", the max. height increase from the center of the front wheels to the rear of car is 4".

